

U:\USA Garage Tools\Updated Ind Upright Cabinet\Ind Upright Cabinet V 2\

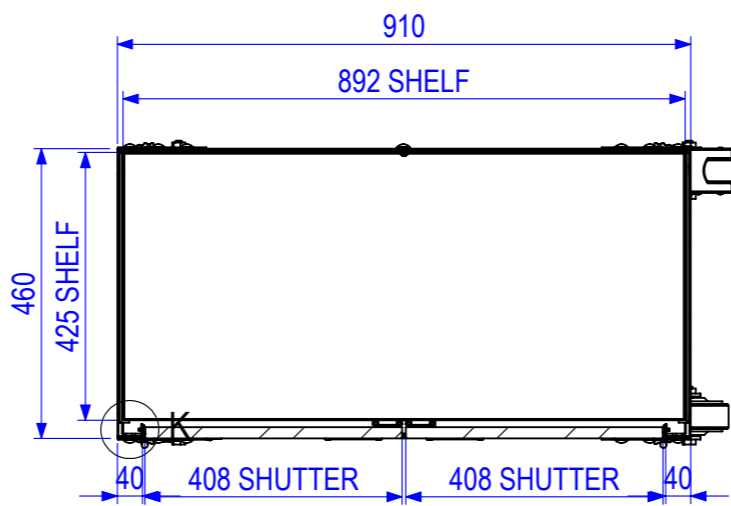
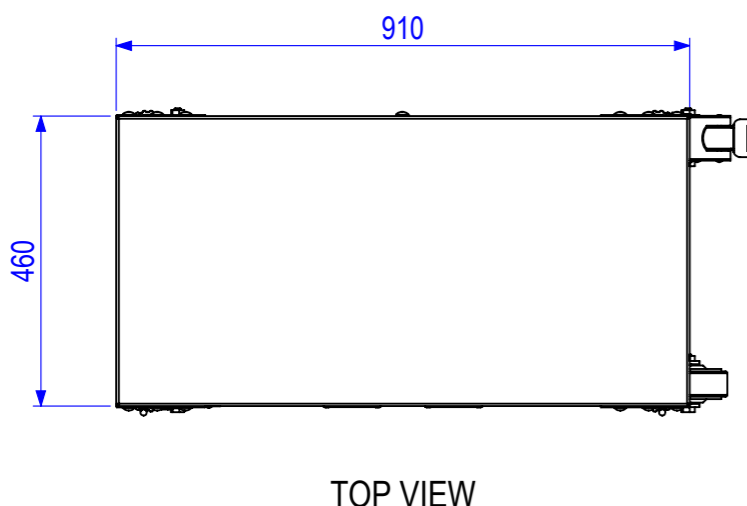
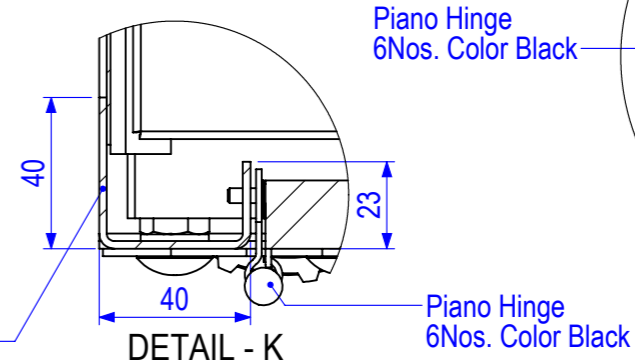
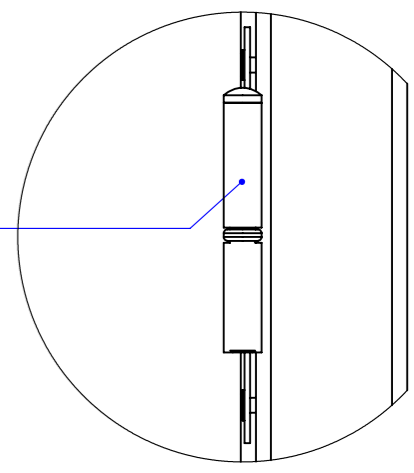
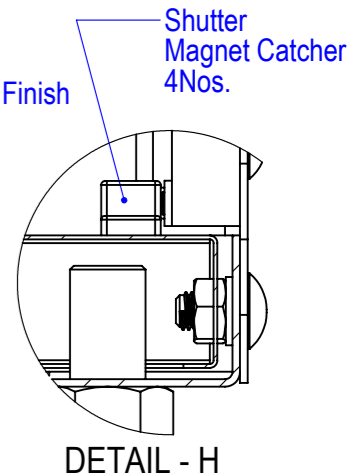
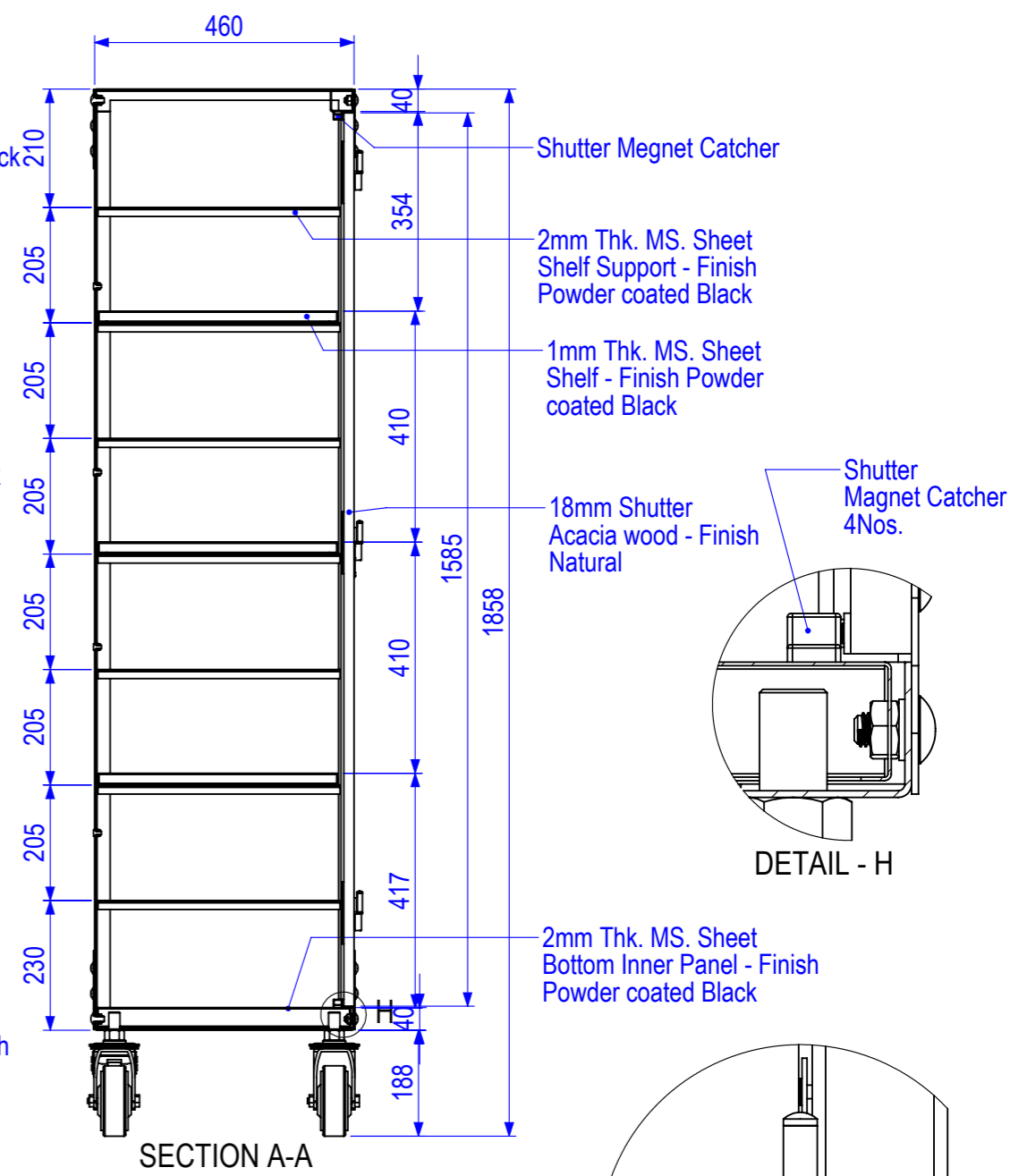
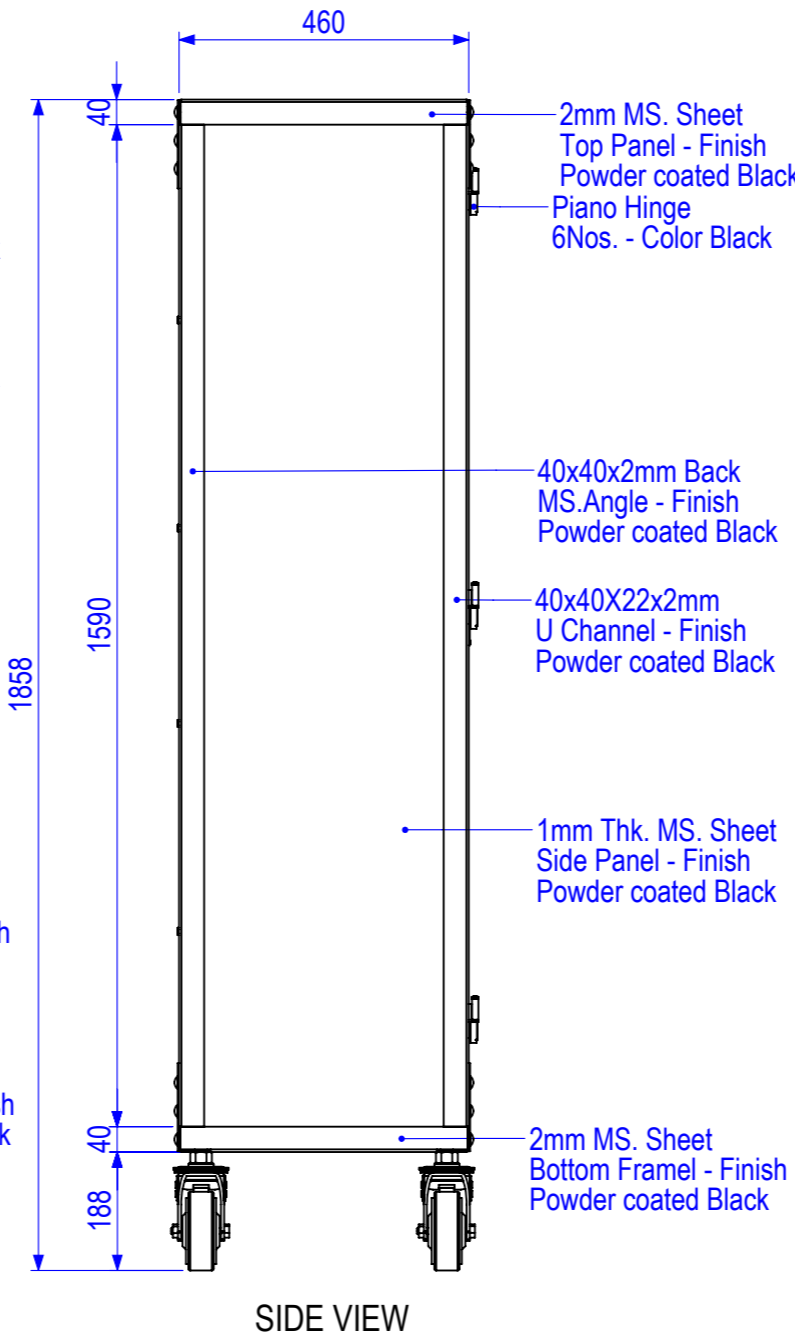
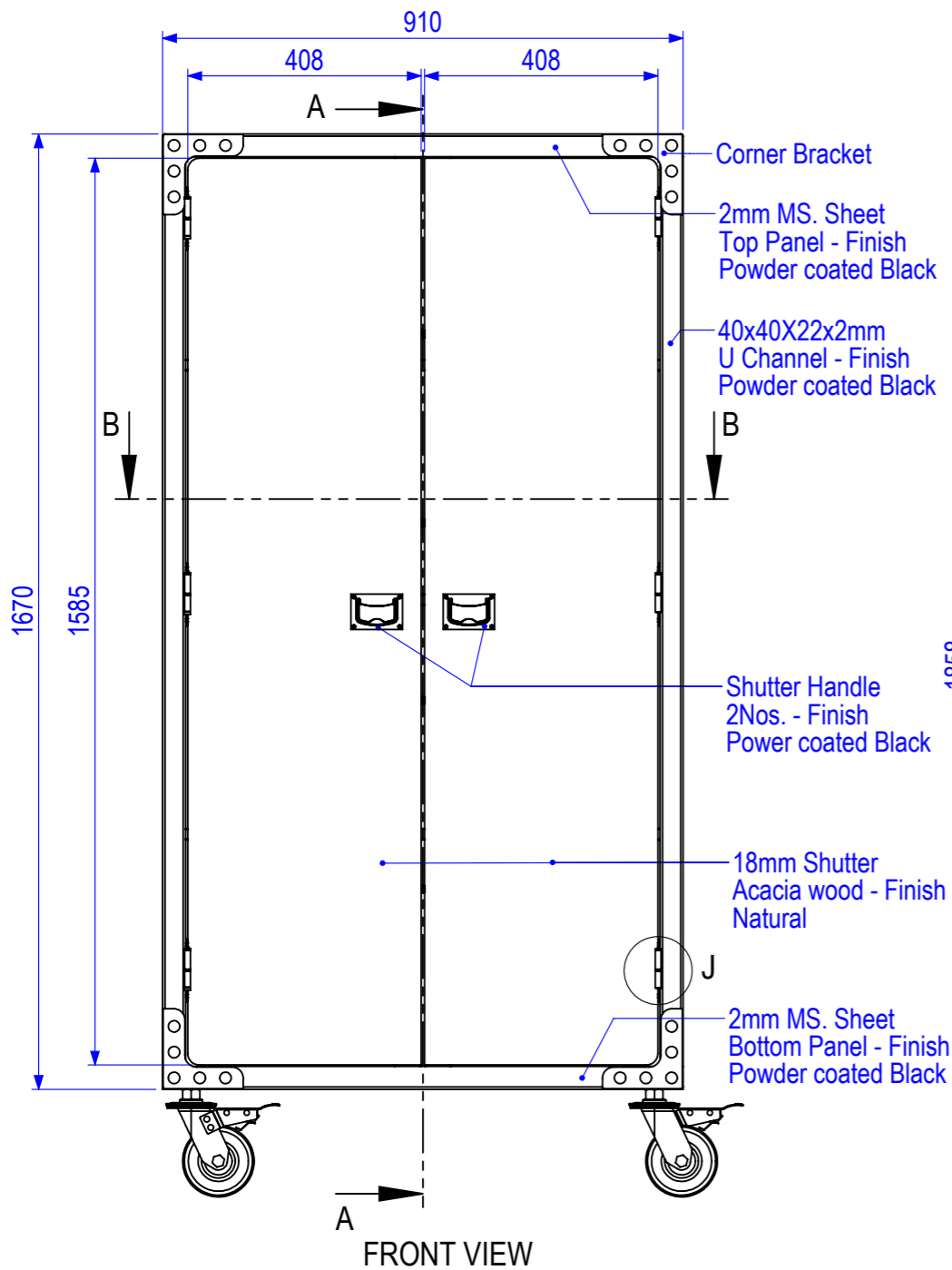

DRAWN	Tahir	SHEET THK.:	-NA-	WEIGHT:	---	S. AREA:	16135693.49mm ²
CHECKED	Harout k	MAT.:	Acacia wood / Metal	FINISH:	POWDER COATED		
APPROVED	Harout k	TITLE: 36" Industrial Free Standing Cabinet					
DATE	04-04-2022						
DWG. NO.	Upright Cabinet	PROJECT:	Upright Cabinet	MODEL:	912x465x1840		
General Tolerance : ± 0.1 mm		INTERMETAL		P.O. Box 474039, Jabel Ali, Dubai Investment Park - 1, Dubai (United Arab Emirates)		SHEET 1 OF 14	
COLOUR	Black	Design & Development Department		Tel: 04-8841650 Fax: 04-8841934		SCALE	REV. 01
QUANTITY	01	ALL DIMENSIONS ARE IN MILLIMETERS AND ALL BEND RADII TO BE MIN. R AT 90° BEND, UNLESS SPECIFIED OTHERWISE					
THIS DRAWING IS THE PROPERTY OF TSSC, NOT TO BE REPRODUCED AS A PART OR WHOLE WITHOUT PRIOR CONSENT OF TSSC							